

雙向展刀搪溝頭 >>> FD

DOUBLE-SLIDE FACING HEAD

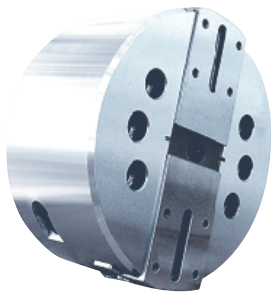

- 進給機構是以曲柄傳動方式為之，進給速度穩定，進給速度與行程的調整亦非常容易。
- 摺動面均經硬化及精密研磨，剛性與耐久性非常良好。
- Feed mechanism is transmitted by Crank type, with steady feed speed. Simple adjustment for feed speed and stroke.
- Matching surfaces of all parts hardened, ground and lubricated.
- 與行控型迴轉油壓缸搭配使用。
- Suitable for using with RS type cylinder.

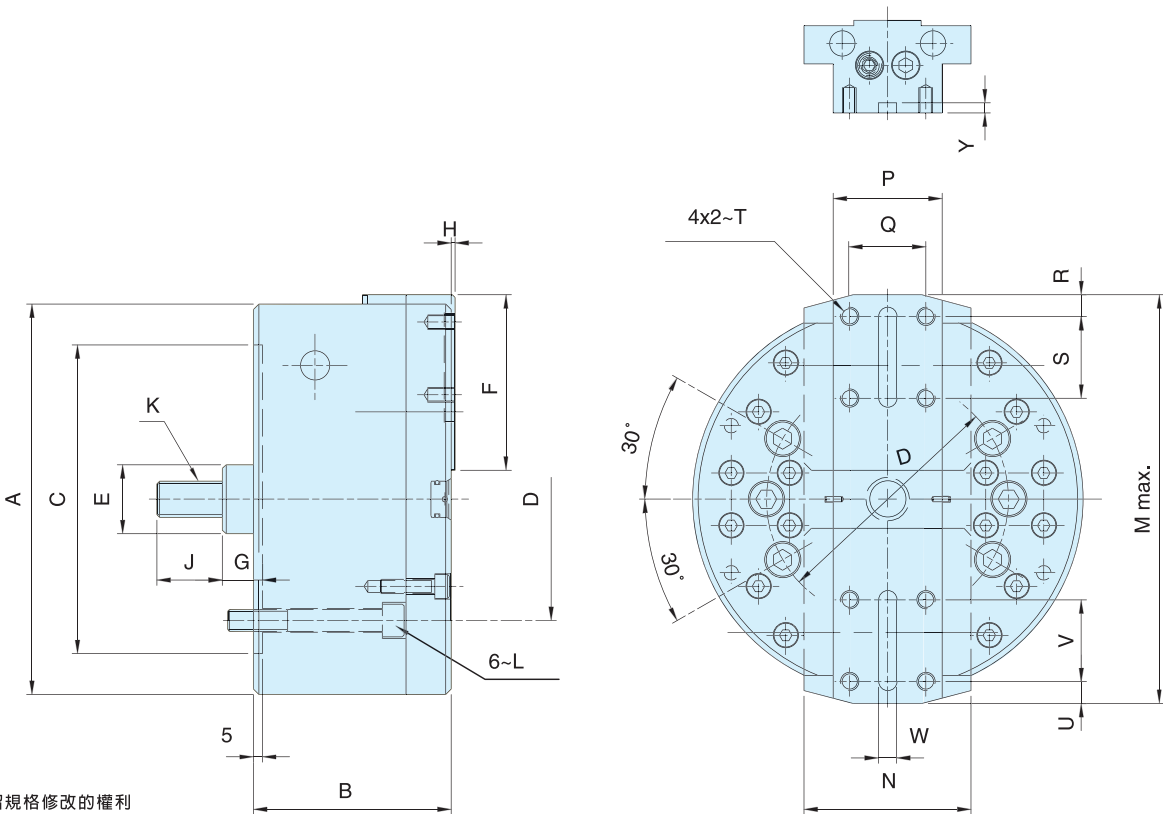

保留規格修改的權利
Subject to technical changes.

規格 Spec. 型號 Model	楔心行程 mm Plunger stroke(Dia.)	滑座行程(直徑) mm Slider stroke(Dia.)	最高迴轉數 min ⁻¹ (r.p.m) Max. speed	最大進給速度mm/min. Max. feed speed	重量 kg Weight	通用油壓缸 Matching cylinder	最大使用壓力 Max. pressure Mpa (kgf/cm ²)
FD-632	20	32	3200	300	13.6	RS-1030N	2.4(24)
FD-840	25	40	2500	240	30.0		3.0(30)
FD-1060	35	60	1800	200	41.5	RS-1040N	

寸法 Size 型號 Model	A	B	C(H7)	D	E	F	G		H	J	K
							max.	min.			
FD-632	168	93	140	104.8	32	76	31	11	2	36	M16x2.0
FD-840	215	109	170	133.4	38	96.5	32.5	7.5			M20x2.5
FD-1060	254	123	220	171.4				110.5		-2.5	4

寸法 Size 型號 Model	L	M	N	P	Q	R	S	T	U	V	W(H8)	Y
FD-632	6-M10x75	188	70	40	25	10	32	M8x15	10	32	6	4
FD-840	6-M12x85	238	90	60	42	12	45	M10x15	12	45	10	6
FD-1060	6-M16x125			65	46	15	50			50		