

主軸頭 >>>



SW-40C

搪銑主軸頭 Boring & Milling Spindles Units

規格 Norms	Model	SW-40C
主軸軸承	Spindle Bearing	7208-2 7207-2
容許轉速	Spindle Max. Speed	8000RPM
上升溫度	Temperature Rise	20°C
容許馬力	Maximum use of motor	2.2KW(3HP)
主軸真圓度	Spindle Roundness	主軸與刀具配合面 MAX: 0.005mm
潤滑方式	Lubrication method	Grease 潤滑油脂
淨重	Net Weight	32kg

SW40C-NT40

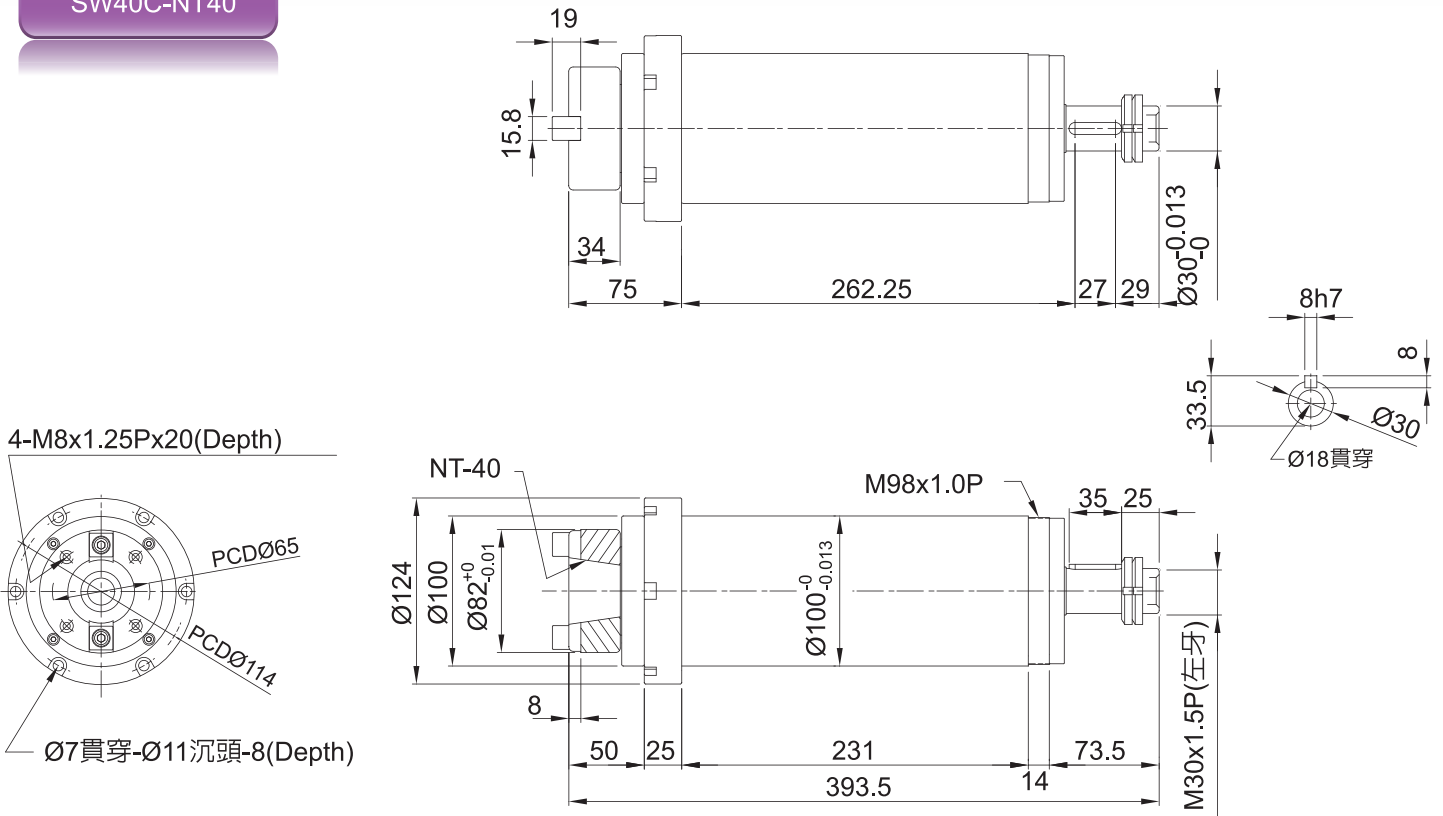

SW40CB-NT40

