

主軸頭 >>>



SW-NN60 / SW-NN80

搪銑主軸頭 Boring & Milling Spindles Units

規格 Norms	Model	SW-NN60	SW-NN80
主軸軸承	Spindle Bearing	NN3012-1 7012DB*1 NN3010	NN3016-1 7016DB*1 NN3014
容許轉速	Spindle Max. Speed	4000RPM	2000RPM
上升溫度	Temperature Rise	20°C	20°C
容許馬力	Maximum use of motor	3.7KW(5HP)	5.5KW(7.5HP)
主軸真圓度	Spindle Roundness	主軸與刀具配合面 MAX: 0.005mm	
潤滑方式	Lubrication method	Grease 潤滑油脂	
淨重	Net Weight	50kg	78kg

主軸頭 | Spindle Machines

SW-NN60-FA50

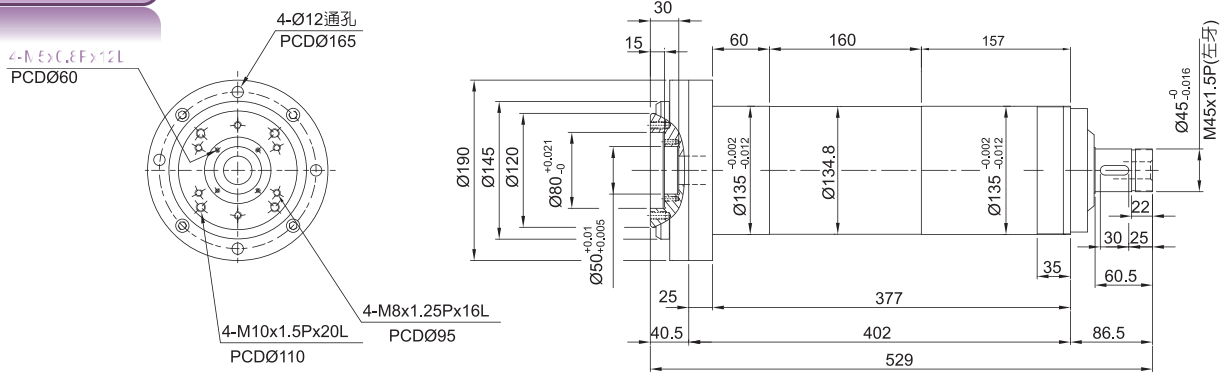

SWNN60B-NT40

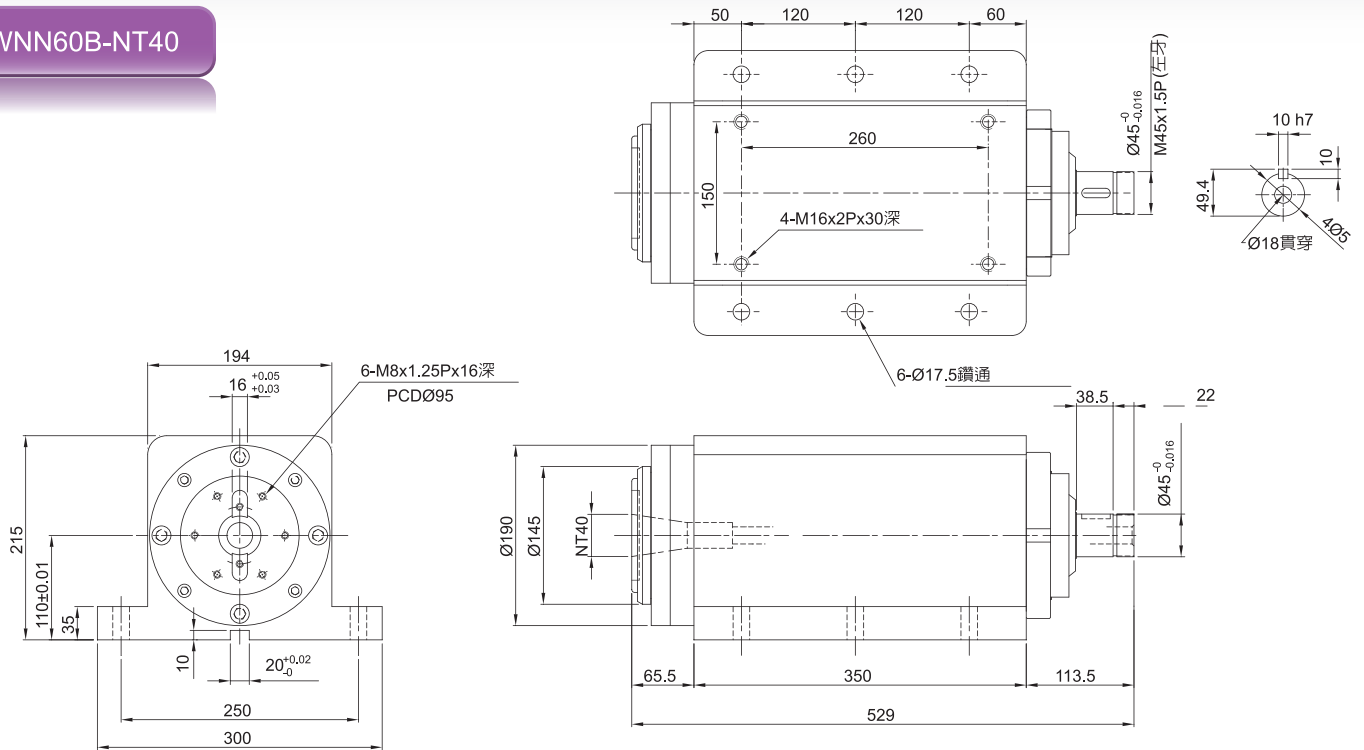

SWNN80-FA75

